

## Gripple Hanger

### Ordering Information

- Specify size. Length is 15 feet.
- Most common hanging method for QF duct due to ease of use.

#### Size by Weight

Up to 22lbs

Up to 100lbs

Up to 200lbs

Up to 495lbs

Up to 715lbs



## Strut Hanger

### Ordering Information

- Tested by MET Laboratories to hold up to 170lbs for 9" and up to 850lbs for 20" without failure.
- For strut channel mounting (strut not included).
- Nut and bolt included.



Galv			SS		
Gauges	Size (in)		Gauges	Size (in)	
	Min. Ø	Max. Ø		Min. Ø	Max. Ø
Std 14	3	24	Std 16	3	24

Ø in.	Std Weight Lbs
3	0.40
4	0.45
5	0.50
6	0.60
7	0.65
8	0.75
9	0.85
10	.95
11	1.00
12	1.10
13	1.20
14	1.15
15	1.30
16	1.35
17	1.40
18	1.50
20	1.80
22	4.10
24	5.00

## Pipe Hanger

### Ordering Information

- Specify size and material.
- Supplied with two halves bolted together.

Ø in.	Weight Lbs	Galv or Carbon Steel			SS		
		Gauges	Size (in)		Gauges	Size (in)	
Min. Ø	Max. Ø		Min. Ø	Max. Ø			
3	0.40	Standard	3	24	Std 16	3	40
4	0.45						
5	0.50	7Ga Carbon Steel	26	40	Std 16	3	40
6	0.60						
7	0.65	7Ga Carbon Steel	26	40	Std 16	3	40
8	0.75						
9	0.85	7Ga Carbon Steel	26	40	Std 16	3	40
10	.95						
11	1.00	7Ga Carbon Steel	26	40	Std 16	3	40
12	1.10						
13	1.20	7Ga Carbon Steel	26	40	Std 16	3	40
14	1.25						
15	1.30	7Ga Carbon Steel	26	40	Std 16	3	40
16	1.35						
17	1.40	7Ga Carbon Steel	26	40	Std 16	3	40
18	1.50						
20	1.80	7Ga Carbon Steel	26	40	Std 16	3	40
22	4.10						
24	5.00	7Ga Carbon Steel	26	40	Std 16	3	40
26	6.10						
28	6.50	7Ga Carbon Steel	26	40	Std 16	3	40
30	6.90						
32	7.30	7Ga Carbon Steel	26	40	Std 16	3	40
34	7.70						
36	8.10	7Ga Carbon Steel	26	40	Std 16	3	40
38	8.50						
40	8.90	7Ga Carbon Steel	26	40	Std 16	3	40

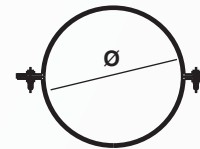

# Pipe Hanger HJ

## Ordering Information

- Specify size and material.
- Clearance hole 7/16".
- Supplied with two halves bolted together.



Ø in.	Weight Lbs	Galv			SS				
		Size (in)		Gauges	Size (in)		Gauges		
		Min. Ø	Max. Ø		Min. Ø	Max. Ø			
3	0.45	Std	14	3	24	Std	16	3	24
4	0.55								
5	0.65								
6	0.75								
7	0.85								
8	0.95								
9	1.05								
10	1.15								
11	1.30								
12	1.45								
13	1.60								
14	1.75								
15	1.90								
16	2.20								
17	2.50								
18	2.85								
20	3.40								
22	4.10								
24	5.00								

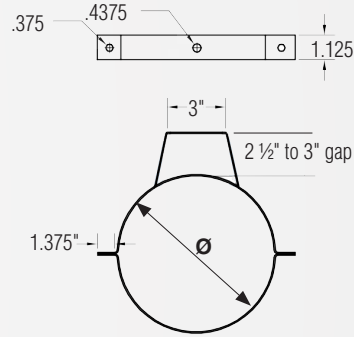

# Clamp Hanger

## Ordering Information

- Specify size and material.
- Cannot be used as a Clamp connection.
- Clearance hole 7/16".

Ø in.	Weight Lbs	Galv			SS				
		Size (in)		Gauges	Size (in)		Gauges		
		Min. Ø	Max. Ø		Min. Ø	Max. Ø			
3	0.45	Std	14	3	24	Std	16	3	24
4	0.55								
5	0.65								
6	0.75								
7	0.85								
8	0.95								
9	1.05								
10	1.15								
11	1.30								
12	1.45								
13	1.60								
14	1.75								
15	1.90								
16	2.20								
17	2.50								
18	2.85								
20	3.40								
22	4.10								
24	5.00								

